

WITHOUT COOLANT (FORM A)

TC DIN 69871

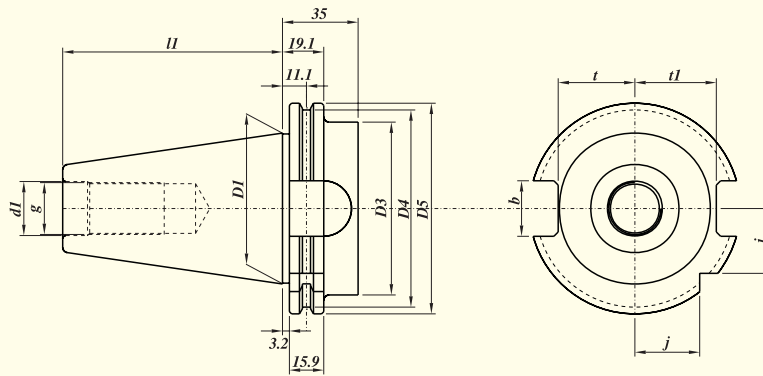

| TAPER | D1 | D3 | D4 | D5 | l1 | g | d1 | t | t1 | b | j |
|-------|-------|----|-------|-------|--------|------|----|------|------|------|------|
| 30 | 31.75 | 45 | 44.3 | 50 | 47.8 | M 12 | 13 | 16.4 | 19 | 16.1 | 15 |
| 40 | 44.45 | 50 | 56.25 | 63.55 | 68.4 | M 16 | 17 | 22.8 | 25 | 16.1 | 18.5 |
| 45 | 57.15 | 63 | 75.25 | 82.55 | 82.7 | M 20 | 21 | 29.1 | 31.3 | 19.3 | 25 |
| 50 | 69.85 | 80 | 91.25 | 97.5 | 101.75 | M 24 | 25 | 35.5 | 37.7 | 25.7 | 30 |
| | | | | | | | | | | | |
| | | | | | | | | | | | |
| | | | | | | | | | | | |
| | | | | | | | | | | | |
| | | | | | | | | | | | |
| | | | | | | | | | | | |
| | | | | | | | | | | | |
| | | | | | | | | | | | |

WITH COOLANT THROUGH CENTER (FORM AD)

FORM AD

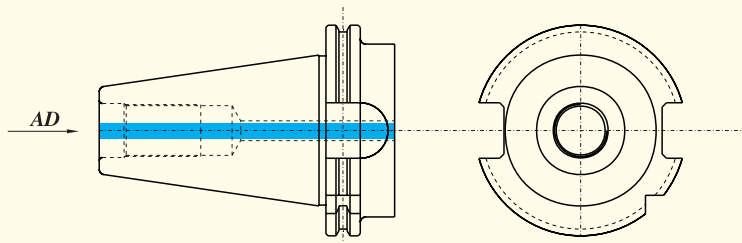

WITH COOLANT THROUGH FLANGE (FORM B)

FORM B

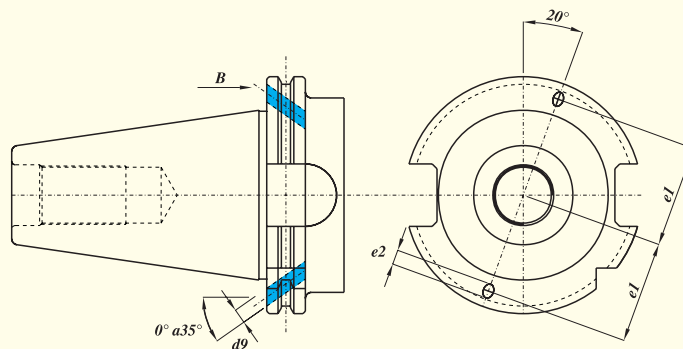

| TAPER | d9 | e1 | e2 |
|-------|----|----|----|
| 40 | 4 | 27 | 5 |
| 45 | 5 | 35 | 6 |
| 50 | 6 | 42 | 7 |