

TC SHANK 'RDO' COLLET HOLDERS COOLANT THROUGH FLANGE

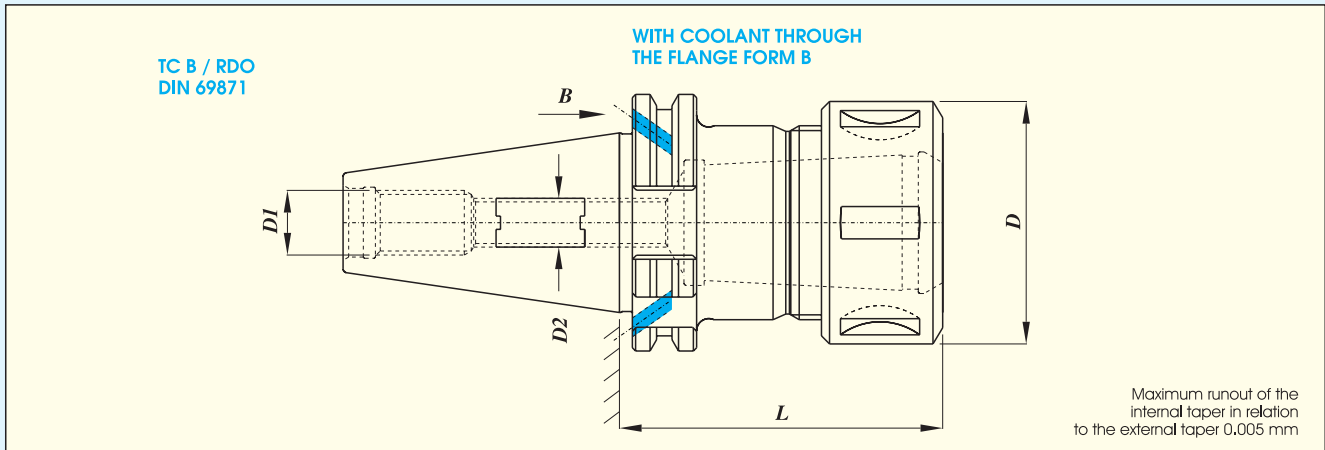

Collet Chuck Designation	Suitable for Collet	Collet Clamping Capacity	L	D1	D2	Nut		Spanner Designation
						D	Designation	
TC 30 B RDO 25070	RDO 25	1,5 - 16	70	M 12	M 10 x 1	43	KM/RDO 25	HS 25
TC 30 B RDO 35070	RDO 35	1,5 - 25	70	M 12	M 12 x 1	60	KM/RDO 35	HS 35
TC 40 B RDO 25070	RDO 25	1,5 - 16	70	M 16	M 10 x 1	43	KM/RDO 25	HS 25
TC 40 B RDO 35070	RDO 35	1,5 - 25	70	M 16	M 12 x 1	60	KM/RDO 35	HS 35
TC 40 B RDO 44090	RDO 44	3,5 - 32	90	M 16	M 18 x 1	72	KM/RDO 44	HS 44
TC 45 B RDO 35070	RDO 35	1,5 - 25	70	M 20	M 12 x 1	60	KM/RDO 35	HS 35
TC 45 B RDO 44070	RDO 44	3,5 - 32	70	M 20	M 18 x 1	72	KM/RDO 44	HS 44
TC 50 B RDO 35085	RDO 35	1,5 - 25	85	M 24	M 12 x 1	60	KM/RDO 35	HS 35
TC 50 B RDO 44090	RDO 44	3,5 - 32	90	M 24	M 18 x 1	72	KM/RDO 44	HS 44

Ordering Example :-
KTA TC 40 B RDO 25070 Coolant through flange/Qty. - 2 Nos.

For Nut
refer page no. 23