

## RDO (OZ) COLLET STANDARD

RDO TYPE COLLETS  
DIN 6388

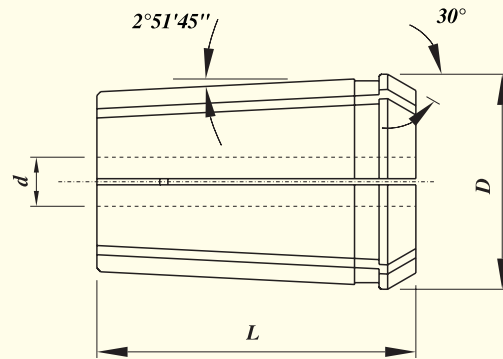

Collet Designation	Bore Range 'd'			Clamping Capacity per set		Each Collet collapse by mm	D mm	L mm
	From mm	To	in steps mm	From mm	To mm			
RDO 25 (OZ 16)	2.0	16.0	0.5	1.5	16.0	0.5	25.50	40
RDO 35 (OZ 25)	2.0	25.0	0.5	1.5	25.0	0.5	35.05	52
RDO 44 (OZ 32)	4.0	32.0	0.5	3.5	32.0	0.5	43.70	60

The collet must always be inserted into the nut before setting the tool into the collet. The collet is fitted inside the nut by applying slight pressure **A**. It is removed by applying **B** to the collet. Never tighten the chuck without a correct size tool shank being present in the collet. Failure to observe this guideline can result in collet breakage.

